

# DETAILED PARAMETER CONFIGURATION

## Envelope diagram

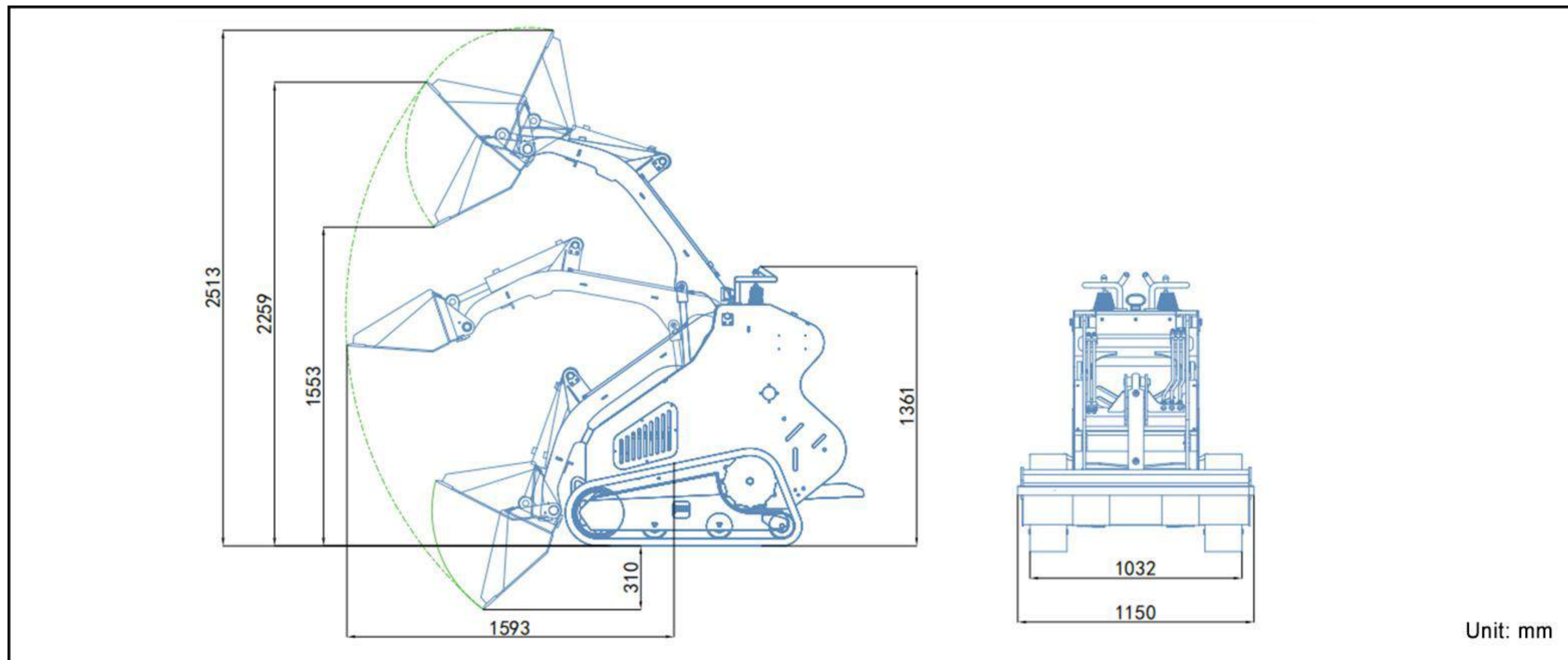

## Product parameter

### Basic performance parameter

Machine working weight	725kg	1595lb
Bucket capacity	0.15m <sup>3</sup>	5.3ft <sup>3</sup>
Rated load mass (safe load)	140kg	308lb
Maximum load mass	280kg	616lb
Travel speed low/high speed	0-2.5Km/h	0-1.55mph
Gradeability	25%	25%
Ground pressure	22.5Kpa	5058psi
Maximum unloading height	1553mm	61.1in
Maximum loading height	2259mm	88.9in
Maximum unloading distance	620mm	24.4in
Minimum ground clearance	129mm	5.1in

### Body

Transport length - with bucket (mm)	2100mm	82.7in
Transport length - without bucket (mm)	1638mm	54.5in
Transport width (mm)	1150mm	45.3in
Transport height (mm)	1361mm	53.6in
Bucket width (mm)	1150mm	45.3in



## POWERED BY Rato R420

### Engine

Engine brand	Rato	Rato
Engine model	R420	R420
Maximum horsepower	11.7ps	11.5hp
Maximum power	8.6kw	8.6kw
Maximum speed	3600rpm	3600rpm
Displacement	0.42L	0.11gal
Number of cylinders	1	1
Cooling method	Air-cooled	Air-cooled
Engine oil change amount	1.1L	0.291gal
Fuel form	Gasoline	Gasoline
Fuel grade	92#	92#
Theoretical fuel consumption	0.8-1.2L/h	0.211-0.317gal

### Hydraulic system

Main pump type/model	Gear pump PGP51044SLP
Main pump brand	Tianjin Walking
Multi-way valve brand	Tengfei
Travel hydraulic motor type	Luko BM5-250
Travel motor brand	Luko